

招标公告

上海振华重工（集团）股份有限公司为下属上海振华船运事业部就集装箱采购进行招标，拟采用公开招标的方式选择供货商，中标单位与上海振华船运有限公司签订合同。本招标邀请对各潜在投标人发布，符合要求的潜在投标人应当在本招标规定的时间内将资格预审文件提交上海振华重工（集团）股份有限公司为进行资格预审。将向资格预审合格的潜在投标人发放标书。

特别提醒：

本招标文件中规定的投标文件内容须在规定时间内打印、加盖公章、扫描上传至中国交建物资采购管理系统，线下不再受理纸质标书！

1. 项目编号：ZPMC(HF)-ZB2023-10-166
2. 项目内容：振华船运事业部集装箱招标
人民币结算，上海振华船运有限公司
采购要求：

采购的 20' 备件集装箱为标准箱，开门方式请见附图（图纸用于参考），为即可正面开门、又能侧面开门，另需增加铲齿孔，铲齿孔中心间距为 2M，单个铲齿孔高 120mm*宽 360mm。

另备件箱顶部和底部需按照图纸要求喷涂 30CM 聚氨酯涂料用于密封外，底部还需贴钢板使备件集装箱底部密封。

备件集装箱须有产品合格证、质量证明书等相关验收检验文件

3. 潜在投标人资格预审

3.1 潜在投标人的资格要求：

- (1) 具有法人资格，能独立承担民事责任；
- (2) 具有良好的商业信誉和财务会计制度；
- (3) 具有履行合同所必需的设备和专业技术能力；
- (4) 近 3 年内有类似相关成功有效业绩 1 例以上（有效业绩的定义：①合同为同类型相关项目；②须提供该业绩合同的复印件（包括但不限于合同首页、双方盖章页、总金额页）；③须提供该业绩合同的项目验收证明（如：业主证明或完工证明、验收报告等）或该业绩合同的所有收款凭证，以证明除验收、质保外其他阶段付款均已支付，（该业绩合同的项目验收证明或该业绩合同的所有收款凭证

可二选一提供)；④所有证明文件在必要时需提供纸质原件备查。);

(5)环境管理、职业健康及安全管理实施情况及绩效说明(拥有 14001\45001 体系证书可免于提供);

(6)近三年发生如生产安全事故,环保事故、分包商员工职业健康问题等被有关部门进行行政处罚或有异常信用记录的,应提供书面分析改进报告。(未如实陈述者,我司有权取消中标资格及其他处罚措施。)

(7)当招标项目涉及国家行政许可要求时,具有相应的行政许可资质;

(8)法律、法规规定的其他条件。

(9)存在行政处罚的单位,根据处罚情况招标小组讨论决定是否通过资格预审。

3.2 资格预审提交材料清单:

(1)企业法人营业执照正副本复印件(具有统一社会信用代码的营业执照,增值税一般纳税人资格证明,代理经销商需同时提供自身及源头生产厂家);

(2)法定代表人、被授权人及联系人身份证复印件;

(3)企业情况简介;

(4)法定代表人授权委托书;

(5)近3年承担的相关业绩证明;

(6)经会计事务所审计的近三年财务会计报告或财务报表;

(7)ISO 9001\14001\45001 及其他管理体系证书(代理经销商需同时提供自身及源头生产厂家);

(8)环境管理、职业健康及安全管理实施情况及绩效说明(拥有 14001\45001 体系证书可免于提供);

(9)近3年发生的生产安全事故的状况描述,尤其说明发生一般及以上生产安全事故的情况;

(10)近3年的环保处置情况描述,尤其说明发生的突发环境事件、受到环保主管部门处罚的情况;

(11)近3年的企业及受控分包商员工的职业健康情况描述,尤其说明发生职业病的情况;

(12)适用时,行政许可资质复印件;

(13)代理商、经销商、服务商等提供授权证书。制造商对授权贸易商经销产品质量责任承担的说明书(授权书已包含可免)。无授权贸易商货源渠道说明及

正品承诺书。（本项要求仅适用于代理商、经销商、服务商）

（14）贸易安全管理告知书。

所有提交的资格预审材料均需加盖潜在投标人公章，所有证书类文件提供扫描件且必须在有效期内。资格预审审查办法采用合格制，凡按照本投标邀请书第三条所要求并完整提供资格预审材料的申请人经招标工作小组审核后均可通过资格预审。未通过资格预审的申请人不具有投标资格。

我司现在对所有供应商进行统一管理，请各潜在意向单位到供应商管理系统（网站地址：<https://srm.zpmc.com/>）或我司官网底部接口登录并进行注册登记。见下图：

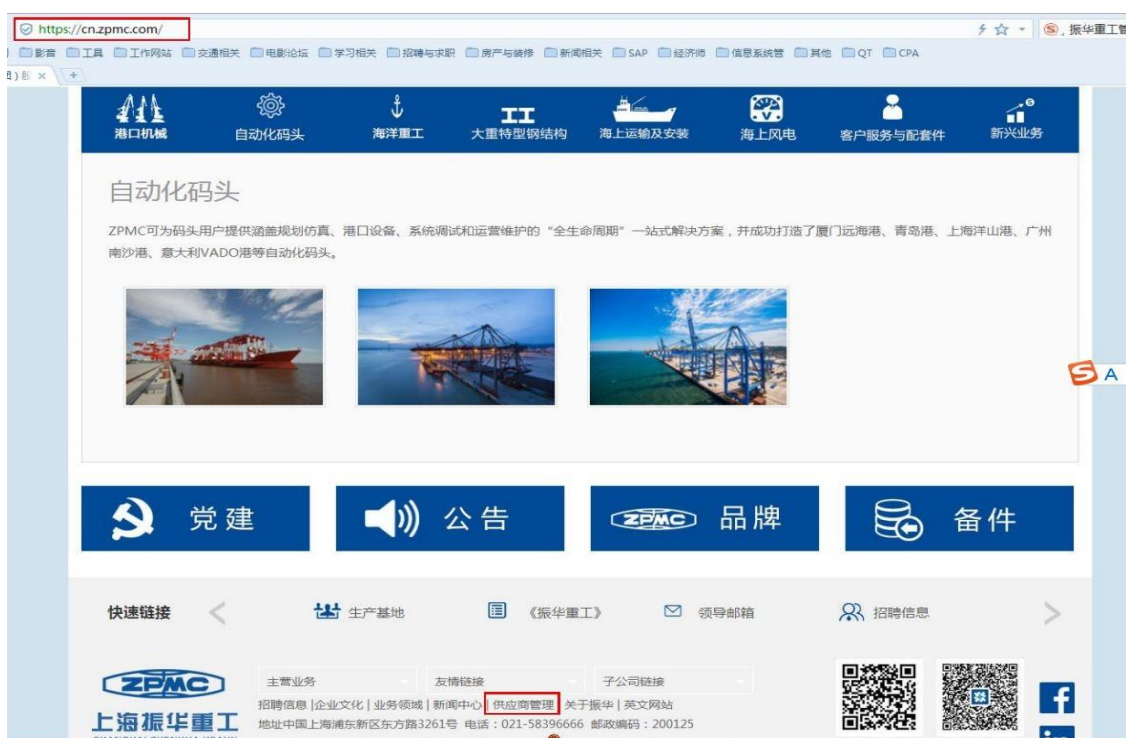

另外，因中交集团要求，我司之后所有的招标项目均将逐步转移至中交供应链管理系统中进行线上招标，请所有潜在意向投标方，除提交上述预审资料外，自行前往中交供应链管理系统（网址：<http://ec.ccccltd.cn/PMS/>）进行在线注册（注册步骤见附件2），以便今后继续参与我司招标项目。具体准入条件和标准如下：

1. 具有法律主体资格，持有营业执照、税务登记证、组织机构代码证，或具有统一社会信用代码的营业执照，并具有增值税一般纳税人资格；
2. 生产商需具有一定的生产能力、规模和相应的技术力量，并具有 ISO9001 质量体系认证证书、ISO14001 环境体系认证证书、ISO45001 职业健康安全体系

认证证书。对于国家强制执行生产许可证制度的行业产品，需提供生产许可证或其他强制认证证明；

3. 贸易商（包括经销商和代理商）需具有固定的经营场所，经营产品质量合格，具有本企业的 ISO9001 质量体系认证证书、ISO14001 环境体系认证证书、ISO45001 职业健康安全体系认证证书。并具有产品生产企业的代理协议或产品销售授权资质；

4. 提供的产品需符合法律规定。对于列入强制性产品认证目录中的产品，需提供产品认证证书；

5. 具有良好的售后服务跟踪体系；

6. 具有良好的资金财务状况；

7. 具有良好的商业信誉，近三年经营活动中无违法记录，并与中交集团无重大法律纠纷记录。

注，如潜在意向投标方如暂不具备质量、环境、职业健康安全三体系认证证书，可以由申请单位填写《供应商让步使用审批单》，经申请单位供应商管理职能部门分管领导审批通过后注册。

3.3 提交材料时间、地点

报名截止时间：2023 年 12 月 18 日上午 10 点之前停止收取报名材料

地 址：中交供应链系统

联 系 人：孙佳

邮箱：sunjia@zpmc.com

电话：021-31190281

4. 经资格预审审查通过的潜在投标人，上海振华重工招标中心通知投标人买标书，标书工本费人民币 0 元（不退还），投标人应在购买前将标书工本费划至招标人指定账户（**保险回单扫描后发给到 sunjia@zpmc.com 的邮箱**）。招标人不接受现金购买标书。标书工本费应当从投标人银行帐户汇出，不得由其分支机构（经法人书面授权提供的除外）或第三方账户转入。资格审查未通过的潜在投标人，资格审查文件不予退还，不通知资格审查结果。

户 名：上海振华重工（集团）股份有限公司

开 户 行：工商银行上海市分行第二营业部

帐 号：1001190709016203966

税 号：91310000607206953D

5. 经审查，资格预审通过的潜在投标人不足 3 方的，上海振华重工招标中心视情况重新发出招标公告/邀请，重新组织资格预审。

6. 潜在投标人应承担所有与准备和参加投标有关的一切费用。不论投标的结果如何，招标人均无义务和责任承担这些费用。

7. 招标人：上海振华重工（集团）股份有限公司

二〇二叁年拾贰月

6058⁰/₋₁₀

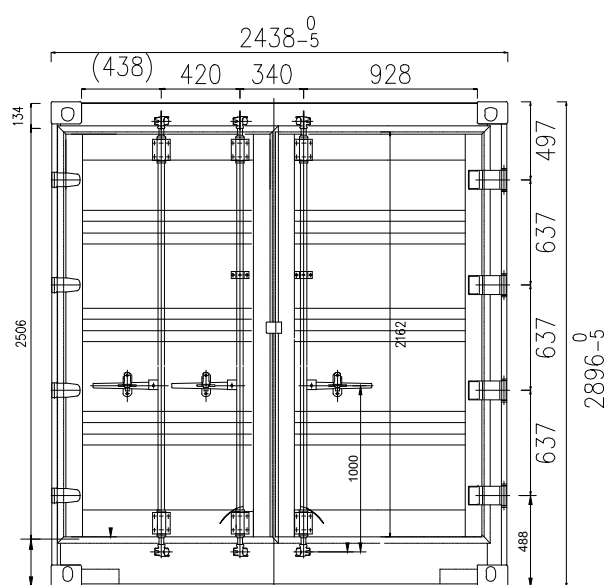
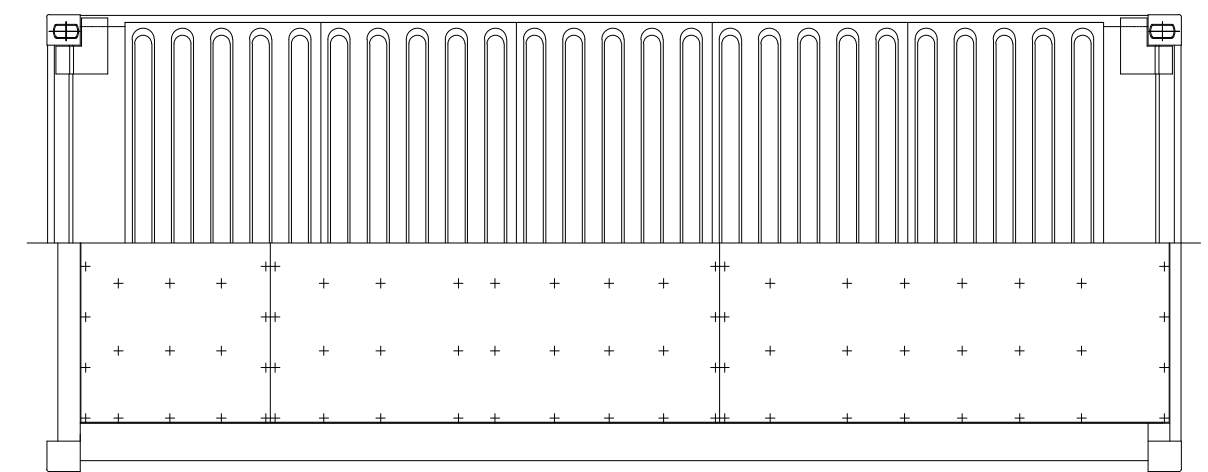
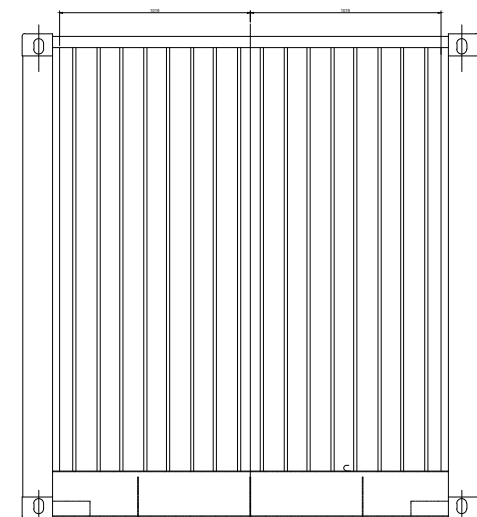
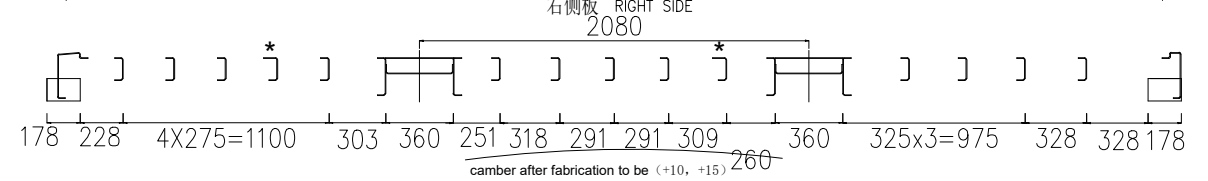
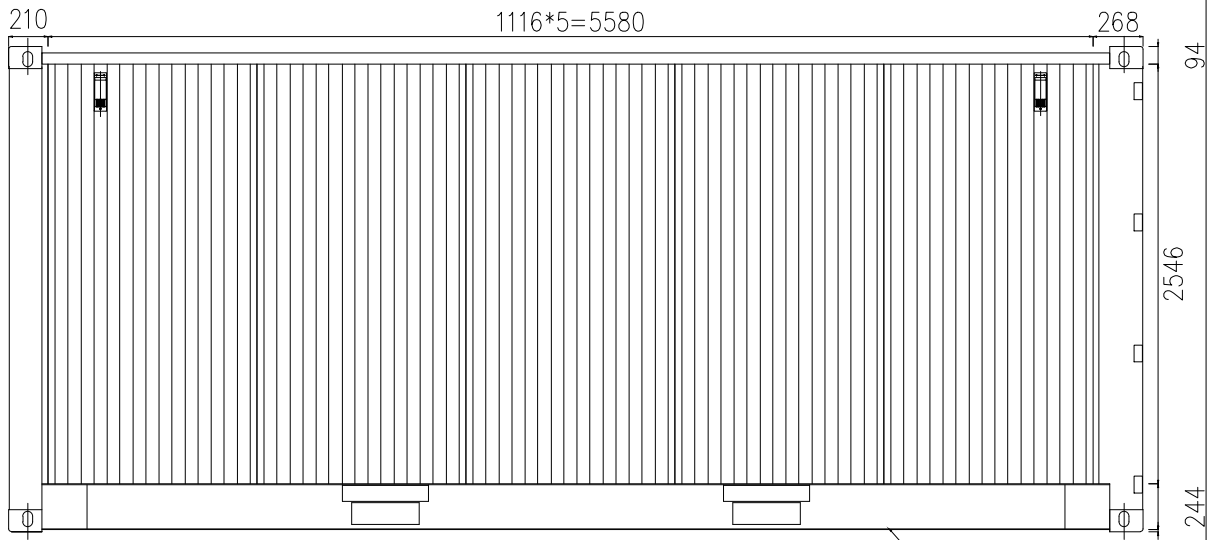
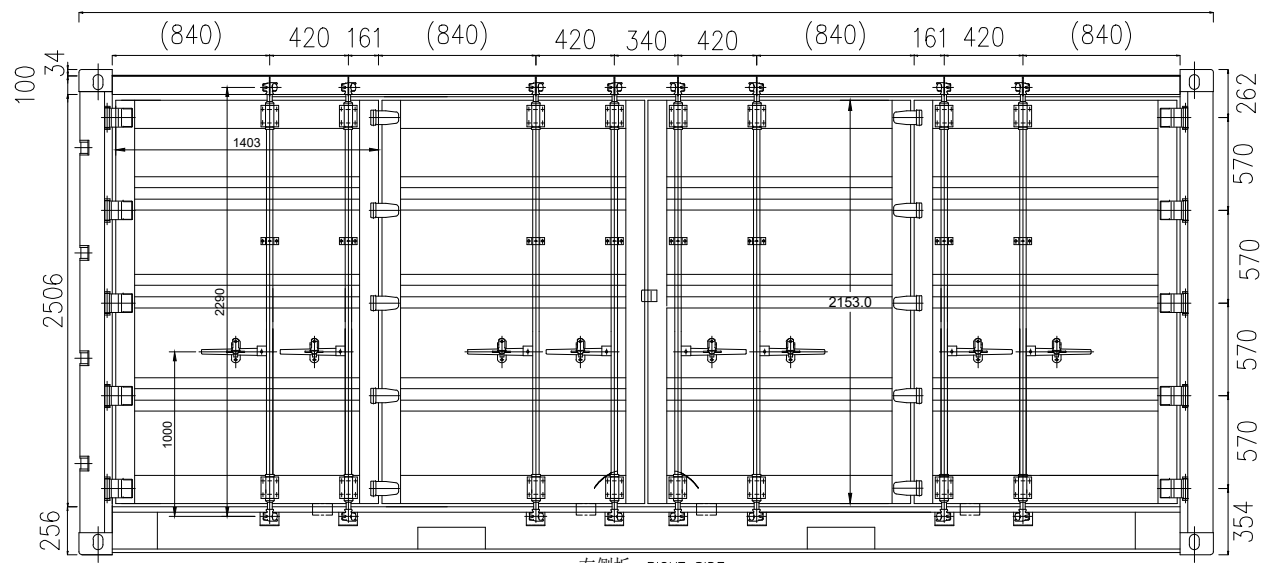

CLASSIFICATION		DIMENSION		
EXTERNAL	LENGTH	6058 ⁰ / ₋₁₀	20'	±0.5"
	WIDTH	2438 ⁰ / ₋₅	8'	±0.5"
	HEIGHT	2591 ⁰ / ₋₅	8'-6"	±0.5"
INTERNAL	LENGTH	5898	19'-4 3/16"	
	WIDTH	2288	7'-6 1/16"	
	HEIGHT	2301	7'-6 9/16"	
SIDE DOOR OPENING	WIDTH	5702	18'-8 1/2"	
	HEIGHT	2191	7'-2 1/4"	
END DOOR OPENING	WIDTH	2281	7'-5 13/16"	
	HEIGHT	2191	7'-2 1/4"	
INTERNAL CUBIC CAPACITY		31 M ³	1094 FT ³	
MAX. GROSS WEIGHT		24000 KGS	52910 LBS	
TARE WEIGHT (±2%)		3180 KGS	7010 LBS	
MAX. PAYLOAD		20820 KGS	45900 LBS	
STACKING TEST LOAD		86400 KGS	190480 LBS	
FLOOR STRENGTH		7260 KG	16000 LBS	

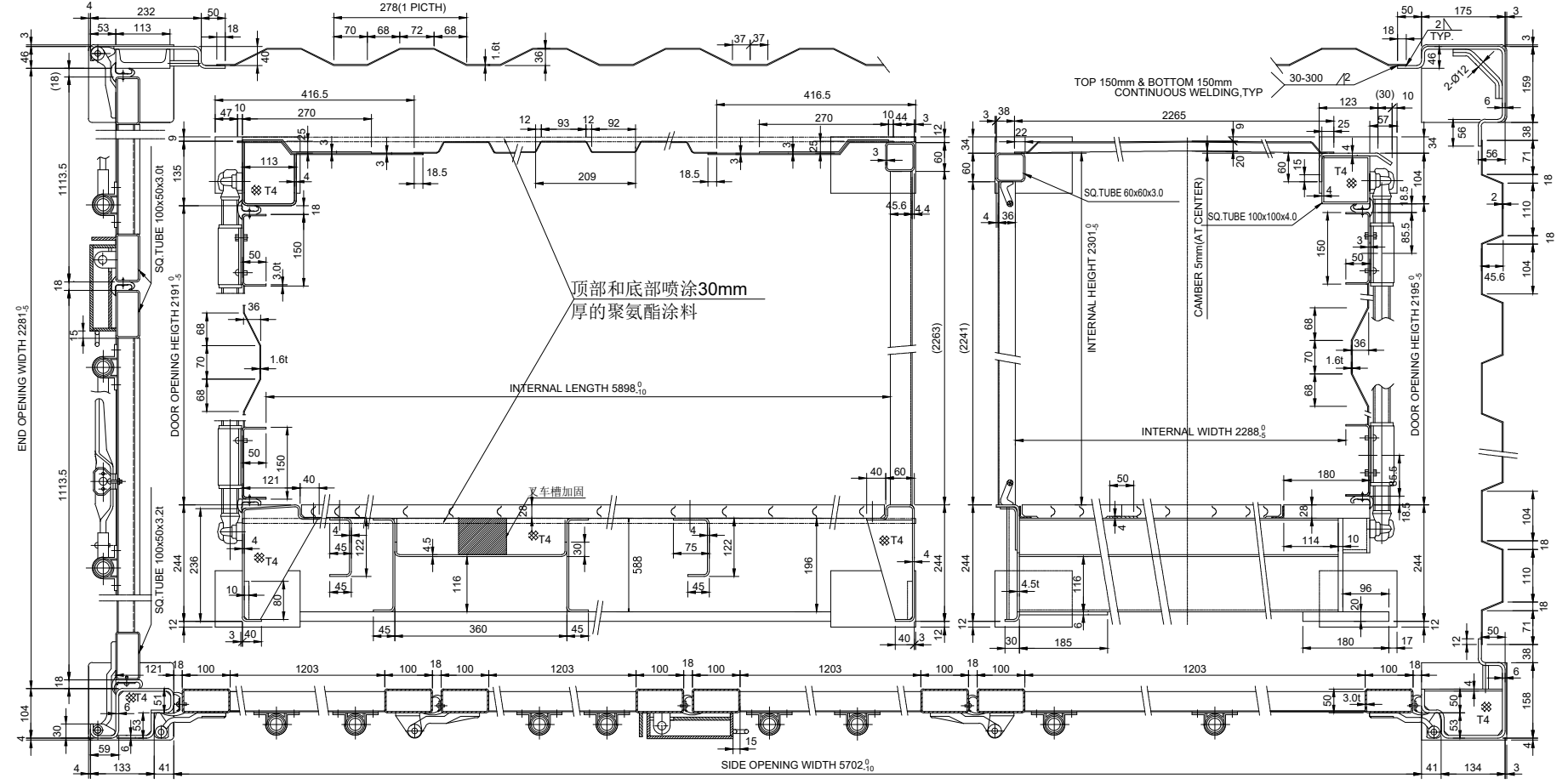

说明:
 1、数量: 40台
 2、箱子顶部喷涂30mm厚聚氨酯涂料, 再用防水胶水做防水; 底部喷涂30mm厚聚氨酯涂料。

ITEM	DESCRIPTION	DWG.NO.	QTY
10	APPLICATION OF SEALANT	20SD-1-01-01	1
9	CONSOLIDATED PLATE	20SD-1-09-01	1
8	ARRANGEMENT OF MARKS	SJCL-20SD-1-09	1
7	ROOF ASSEMBLY 顶板组合	SJCL-20SD-1-08	1
6	DOOR ASSEMBLY 门板组合	SJCL-20SD-1-07	1
5	REAR ASSEMBLY 后端组合	SJCL-20SD-6-06	1
4	FRONT ASSEMBLY 前端组合	SJCL-20SD-1-05	1
3	SIDE ASSEMBLY 侧板组合(右)	SJCL-20SD-7-04B	1
2	SIDE ASSEMBLY 侧板组合	SJCL-20SD-7-04A	1
1	BASE ASSEMBLY 底盘	SJCL-20SD-7-02	1

DRAWN BY	DESIGNED BY	CHECKED BY	APPROVED BY	GENERAL ASSEMBLY
				总图
SCALE:	DATE:	OWNER: Royal Wolf		
1:30				

附件 1.

项目投标报名表

上海振华重工（集团）股份有限公司：

我单位申请参加贵单位组织的集装箱的投标（招标编号：ZPMC(HF)-ZB2023-10-166），并遵守招标投标程序及有关规定。我方拟派担任本项目的联系人，全权代表我单位处理本次投标中的有关事务，并签署全部有关文件、协议及合同。我单位对授权联系人的签名负全部责任。具体情况如下，如有失实，由我方承担相应责任。

投标单位（人）名称	
企业性质	
注册地址	
项目联系人	
联系电话/手机	
传 真	
E-mail	
通 信 地 址	
邮 政 编 码	
报 名 单 位 （ 公 章 ）：	
备注：以上《投标报名表》信息必须完整准确填写，若由于投标方报名信息填写不完整准确造成的一切后果，招标方一概不负责。	

法定代表人授权委托书

上海振华重工（集团）股份有限公司：

兹委派我单位_____（姓名）（身份证号：_____）参加贵单位组织的集装箱项目招标活动（招标编号：ZPMC(HF)-ZB2023-10-166），全权代表我单位处理本次投标中的有关事务，并签署全部有关文件、协议及合同。

如若中标，我方授权_____（姓名）（身份证号：_____）与贵方签署各类经济合同。

被授权人对外的一切活动均代表我公司行为，我方将对其行为负全部法律责任。

本授权书于签字盖章后生效，在贵部收到撤销授权的书面通知以前，本授权书一直有效。被授权人签署的所有文件不因授权的撤消而失效。

授权代表人无转委权。特此委托。

附全权代表情况（身份证复印件）：

授权单位（盖章）：

法定代表人（签字）：

日期： 年 月 日

贸易安全管理告知书

Trade Safety Management Notification

尊敬的供应商 Dear supplier:

我司目前为海关高级认证企业，作为与我司合作的商业伙伴，现要求贵司按照海关高级认证中有关贸易安全标准优化要求完善自身的贸易安全管理，具体标准请见附件，请知晓本告知书和附件内容要求，对本告知书盖章或签字后回传。

Our company is an AEO senior certification enterprise. As a business partner of our company, now your company is required to improve your own trade safety management according to the optimization requirements of the relevant trade safety standards in the AEO senior certification. Please see the attachment for the specific standards. Please kindly be aware of the requirements of this notification and the attachment and give the sealed or signed notification to us.

上海振华重工（集团）股份有限公司

Shanghai Zhenhua Heavy Industries Co., Ltd.

振华重工 ZPMC:

我司已阅读并知晓贵司以上要求并将遵照执行。

We have read and understood the above requirements of your company.

商业伙伴名称 Name of Business Partner: _____

被授权人签字 The Signature of the Authorized Person: _____

日 期 Date: _____

附件 Attachment:**海关认证企业贸易安全标准****Trade Safety Standard of AEO Enterprise****1.场所安全控制方面****1. Safety of material handling site and warehouse**

有检查、阻止未载明的货物和未经许可的人员进入场所、货物装卸和储存区域的书面制度和程序；进出口货物进出的区域设有隔离措施，以防止未经许可的人员进入。

There is a checking procedure to prevent unmarked goods and unauthorized personal access to site specific. There are written policies and procedures for cargo handling and storage areas. There are isolation measures for import and export goods in and out of the region, preventing unauthorized access.

1.1 大门和传达室：车辆、人员进出的大门配备人员驻守。

1.1 Gate: Guard stationed for both staff and vehicle entrance & exits.

1.2 建筑结构：建筑物的建造方式能够防止非法闯入。定期对建筑物进行检查和修缮，确保其完好无损。

1.2. Building structures: The way buildings are built can prevent illegal entry. Regular inspection and repair of buildings to ensure that the buildings are in good condition.

1.3 照明：企业生产经营场所应配备充足的照明，包括以下区域：出入口，货物装卸和储存区，围墙周边及停车场/停车区域。

1.3. Lighting: The sites of production and business operation are equipped with adequate lighting, including the following areas: entrances and exits, cargo handling and storage area, fence and parking lot / parking area.

1.4 报警系统及视频监控摄像机：装配报警系统和视频监控摄像机，监测以下区域：出入口，货物装卸和储存区，围墙周边及停车场/停车区域。监控保留 45 天以上。

1.4. Safety alarm and intelligent video surveillance system: In order to prevent unauthorized access to cargo storage and working areas, safety alarm and intelligent video surveillance system cover following areas: entrance & exits, cargo handling and storage areas, fence and parking lot / parking area.

1.5 存储区域：在货物装卸和储存区域，以及用于存放进出口货物的区域，设有隔离设施，以阻止任何未经许可的人员进入。

1.5. Storage area: Isolation facilities should be set to prevent unauthorized personnel access in the cargo handling and storage areas, as well as in the storage area of goods to be imported and exported.

1.6 锁闭装置及钥匙保管：所有内外窗户，大门和围栏都设有足够数量的锁闭装置。管理层或者保安人员保管所有锁和钥匙。

1.6. Locking devices and key keeping: All internal and external windows, doors and fences should be equipped with sufficient locking devices. Management or

security personnel keep all locks and keys.

2.进入安全控制方面

2. Safety of personnel and vehicle access

企业实行门禁管理。有员工、访客进出的书面制度和程序，保护公司的财产。

Enterprises implement access control management. There are written systems and procedures to implement the entry and exit of employees and visitors and to protect the company's assets.

2.1.员工:有员工身份识别系统，对员工进行身份识别和入职控制。对员工和访客的身份标识(如钥匙、门卡等)的发放和回收进行统一管理和登记。

2.1. Employees: There is an employee identification system, which carries out identification and entry control for employees. Unified management and registration are carried out for the issuance and recycling of identity marks of employees and visitors (e.g. keys, key cards, etc.).

2.2.访客:进入企业的访客应检查身份证照片并进行登记。访客应佩戴临时身份证件，并由内部工作人员陪同。

2.2.Visitors: Visitors entering the enterprise should check the ID card with photos and register. Visitors should wear temporary identification and be accompanied by internal staff.

2.3.未经许可进入的身份不明人员:未经许可进入的身份不明人员有识别、查询和确认的程序，员工应及时报告可疑人员的进入。

2.3. Unidentified persons without entering permission: There are procedures for identification, inquiry and confirmation of unidentified persons without entering permission. Employees should report entry of suspicious person in time.

3.人员安全

3. Personnel safety

公司有书面的制度和程序来审查待聘员工和定期审查现有员工，并提供一份员工名单，包括姓名、出生日期、担任职位、身份证号码，可以实时更新。

The company has written systems and procedures for reviewing employees to be hired and regularly reviewing existing employees, and provides a list of employees, including name, date of birth, id number for holding positions which can be updated in real time.

3.1.入职前验证:在聘用员工之前，需要对申请信息(如工作经历、推荐信等)进行验证。

3.1. Pre-employment verification: Before hiring an employee, verification of the application information (e.g. employment experience, recommendation letter, etc.) is needed.

3.2.背景调查:在录用员工之前，要对其是否有犯罪记录等安全背景进行检查或调查。一旦录用，要根据员工的工作表现，对敏感、重要岗位的员工进行定期审查和重新调查。

3.2. Background survey: Before hiring an employee, it should be checked or investigated for the safety background such as whether there is a criminal record or not. Once hired, regular reviews and re-surveys should be conducted to employees in

sensitive and important positions on the basis of employee performance.

3.3.员工离职程序:员工离职或停职,应及时追回工作证件和设备,禁止员工进入企业生产经营现场,禁止员工使用企业信息系统,有书面制度和程序。

3.3. Procedure of the employees leave: There are written systems and procedures for timely recovery of work certificates and equipment for employees leaving or suspending their jobs, who should be forbidden to enter the production and operation sites of enterprises and to use enterprise information systems.

3.4.安全培训:对员工进行供应链安全意识的日常培训,他们需要了解企业对出现安全情况的反应和报告程序。

3.4. Safety training: Employees should be provided with daily training on supply chain security awareness. They need to understand the enterprise's response to a certain situation and reporting procedures.

4.商业伙伴的安全

4. Safety of business partner

企业有书面的制度和程序来评估、要求和检查商业伙伴的供应链安全。

Enterprises have written systems and procedures for assessing, requiring, and inspecting the supply chain safety of business partners.

4.1.综合评估:在筛选商业伙伴时,应按照本认证标准对商业伙伴进行综合评估,重点关注合规性和贸易安全,有书面制度和程序。

4.1. Comprehensive assessment: In screening business partners, a comprehensive assessment of business partners should be conducted in accordance with this certification standard, focusing on compliance and trade safety, with written systems and procedures.

4.2.书面文件:要求商业合作伙伴按照本认证标准在合同、协议或其他书面材料中优化和完善贸易安全管理。

4.2. Written documents: Commercial partners are required to optimize and improve trade safety management in contracts, agreements or other written materials in accordance with this certification standard.

4.3.监督检查:定期监督或检查业务合作伙伴对贸易安全要求的遵守情况,还需要书面制度和程序。

4.3. Monitoring and Inspection: Monitoring or inspecting business partners' compliance with trade safety requirements regularly. Written systems and procedures are also required.

5.货物安全控制方面

5. Cargo safety

对于货物的运输、搬运和存放过程制定了相应的控制措施和程序。

Enterprises have measures and procedures to ensure the integrity and safety of goods in the supply chain during transportation, handling and storage.

5.1.货物的装运和验收:到达的货物必须与货物单据上的信息相符。货物的重量、标签、件数或箱数应核实。离岸货物应当与购货单或者发货单的内容核对。在货物交付的关键环节设置签章、盖章等保护制度。

5.1. Shipment and acceptance of goods: The goods arriving must correspond to the

information on the goods document. The weight, label, number of pieces or number of boxes of the goods should be verified. Offshore goods should be verified with the contents of purchase or shipment orders. Protecting system such as signing and sealing should be set in the key link of the goods delivery.

5.2. 货物差异: 在出现货物溢、短装或者其他异常现象时, 本企业有相应的应对措施并有书面制度和程序。

5.2. Discrepancy of the goods: The enterprise should report timely or take corresponding measures when the goods are found short or over or abnormal. Written systems and procedures are also required.

6. 集装箱安全控制方面

6. Container safety

有措施和程序来确保集装箱的完整性, 以防止未经授权的货物或人员进入。

There are measures and procedures to ensure the integrity of containers so as to prevent the entrance of unauthorized goods or personnel.

6.1. 集装箱检验: 在装货前检查集装箱结构的物理完整性和可靠性, 包括门的锁闭系统的可靠性, 并做好相关登记。建议进行七点检查, 即按照以下顺序检查集装箱: 前墙、左侧、右侧、地板、顶部、内/外门、外/起落架。

6.1. Container inspection: The physical integrity and reliability of the container structure, including the reliability of the locking system of the door should be inspected before loading. Relevant registration should be made. A seven-point inspection is recommended, which is to check containers in the following order: front wall, left side, right side, floor, top, inside/outside door, outside/landing gear.

6.2. 集装箱封条: 对装货集装箱施加高安全度的封条, 所有封条都符合或者超出现行 PAS ISO 17712 对高度安全封条的标准, 封条有专人管理、登记。有施加和检验封条的书面制度和程序, 以及封条异常的报告机制。

6.2. Container seal: High security seals should be attached to loaded containers. All seals should meet or exceed the current PAS ISO 17712 standards for high security seals, being supervised and sealed by specially-assigned person. There are written policies and procedures applied for attachment and inspection of the seal. Reporting mechanism should be set for abnormal seal.

6.3. 集装箱存储: 本企业集装箱保存在安全的区域, 以防止未经许可的进入或者改装, 有报告和解决未经许可擅自进入集装箱或者集装箱存储区域的程序。

6.3. Container storage: The container should be kept in a safe area to prevent unauthorized entry or modification. Procedures should be set for reporting and resolving unauthorized access to containers or container storage areas.

7. 运输工具安全控制方面

7. Vehicle safety

企业有书面制度和程序, 以确保运输(拖车和手推车)的完整性, 并防止未经授权的人员或物品混入。

Enterprises have written systems and procedures to ensure the integrity of transport (trailers and hand cars) and to prevent unauthorized persons or items from being mixed in.

7.1. 运输工具的检查程序：有专门程序或制度检查出入运输工具，防止藏匿可疑物品。

7.1. Transport inspection procedures: There should be a specific program or system to check all transportation vehicles, preventing the concealment of suspicious items.

7.2. 运输工具存储：运输工具停放在安全的区域，以防止未经许可的进入或者其他损害，有报告和解决未经许可擅自进入或者损害的程序。

7.2. Transportation vehicles storage: Transportation vehicles should be parked in a safe area to prevent unauthorized entry or other damages. Procedures should be set for reporting and resolving unauthorized entry or damage.

7.3. 司机身份核实：在货物被接受或者发放前，应对装运或者接收货物驾驶员进行身份认定。

7.3. Verification of driver's identity: The driver's identity should be verified before the goods are received or issued.

8. 危机管理

8. Crisis management

企业有书面的系统和程序来处理异常情况，如灾害或紧急安全事件。

Enterprises have written systems and procedures for dealing with abnormal situations such as disasters or emergency safety incidents.

8.1. 应急机制对于灾害或紧急安全事件等异常情况，已设置应急程序或机制进行报告和处理。

8.1. Emergency mechanism: Emergency procedures or mechanisms have been set for reporting and dealing with abnormal situations such as disasters or emergency safety incidents.

8.2. 应急培训：应对员工安排应急培训。

8.2. Emergency training: Emergency training should be arranged for employees.

8.3. 异常报告：发现灾害、紧急安全事故等异常情况、违法或可疑活动的，应当向海关或其他相关执法机构报告。

8.3. Report of the abnormal: If any abnormal situation, illegal or suspicious activity, such as disaster or emergency safety accident, is found, it shall be reported to the Customs or other relevant law enforcement agencies.